

形状及び寸法

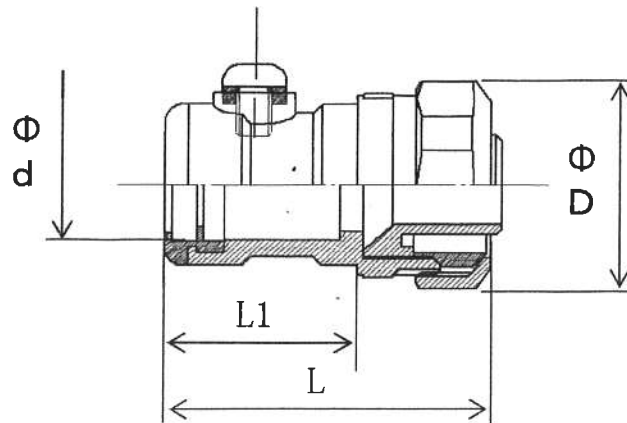

薄鋼用 (PWC)

単位 : mm

	$L \pm 0.5$	$L1 \pm 0.2$	$D \pm 0.2$	$d \pm 0.2$	重量 (g)
17-19	56	25	37.2	19.6	122
24-25	64	31	46.1	25.9	190
30-31	71.5	40	54.0	32.3	280
38-39	79	42	63.8	38.6	405
50-51	88	47	78.2	51.3	605
63-63	95	51	93.0	64.2	935
76-75	101	53	108.3	76.9	1185

厚鋼用 (PWG)

単位 : mm

	$L \pm 0.5$	$L1 \pm 0.2$	$D \pm 0.2$	$d \pm 0.2$	重量 (g)
17-16	57	25	37.2	21.9	135
24-22	64	31	46.1	27.3	180
30-28	73	40	54.0	33.9	280
38-36	81	42	63.8	42.7	415
50-42	89	47	78.2	48.7	605
50-54	89	47	78.2	60.4	730
63-54	96	51	93.0	60.4	950
76-70	102	53	108.3	76.3	1135
83-82	117	54	121.5	88.7	1530
101-92	125	62	145	101.6	2360
101-104	131	68	145	114.3	2360